

- (21) G. Melone, A. Vecchi, G. Pagani, and E. Testa, *J. Org. Chem.*, **25**, 859 (1960).  
 (22) R. D. Bach and J. M. Domagala, *Tetrahedron Lett.*, 4025 (1976).  
 (23) John M. Domagala was the recipient of a National Science Foundation Predoctoral Fellowship.

John M. Domagala,<sup>23</sup> Robert D. Bach\*  
 Department of Chemistry, Wayne State University  
 Detroit, Michigan 48202  
 Received September 12, 1977

### The 1,3-Dimethyltriazaallyl Radical

Sir:

Although a number of neutral radicals with the unpaired electron interacting with two adjacent nitrogen atoms have been detected by ESR spectroscopy,<sup>1-8</sup> little is known about radicals with three adjacent nitrogen atoms. Recently Roberts and co-workers<sup>9</sup> detected some radical of this type by addition of silyl radicals to alkyl azides. Two alternate structures were proposed, viz.,

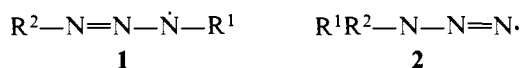

but the authors favored structure **2** since it appeared to be in better agreement with the ESR parameters. We have now obtained a radical having structure **1** which is different from those obtained by Roberts et al.<sup>9</sup>

Photolysis in the cavity of an ESR spectrometer of a mixture of di-*tert*-butyl peroxide (Bu<sup>t</sup>OObu<sup>t</sup>) and 1,3-dimethyltriazeno<sup>10</sup> (CH<sub>3</sub>NHN=NCH<sub>3</sub>) in a variety of solvents (cyclopropane, isooctane, methylcyclohexane) at about -100 °C yields a radical having the ESR spectrum shown in Figure 1 (the computer simulation obtained with hfs constants of Table I is also displayed). On enhancing the ESR signals, two more experimental lines are detected, as predicted by the spectral simulation. The radical disappears when the temperature is raised (cf. ref 9). The equivalence of two nitrogens and of the two methyls, plus the large couplings with the methyl hydrogens and the fact that the radical has been produced by a typical hydrogen abstraction reaction, seems to confirm that we actually detect the first triazaallyl radical.

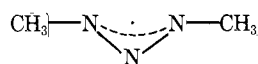

None of the above-mentioned features were observed for the radicals derived from additions to alkyl azides.<sup>9</sup> It is also worth mentioning that photolysis of CH<sub>3</sub>NHN=NCH<sub>3</sub> in absence of (Bu<sup>t</sup>O)<sub>2</sub> produces the methyl radical, whose spectrum was also detected in some samples superimposed to the radical of Figure 1.

As for the electronic configuration of the 1,3-dimethyltriazaallyl radical, there are two possibilities worth discussion. In the allyl radical the unpaired electron can only be localized on a  $\pi$  system; however, in its nitrogen analogue the presence of a molecular orbital (MO) formed by the nitrogen lone pairs having an energy comparable with that of the  $\pi$  system leads to two alternate possibilities: (i) a  $\pi$  radical, where only the 2p<sub>z</sub> atomic orbitals of the three nitrogens are involved in building

Scheme I

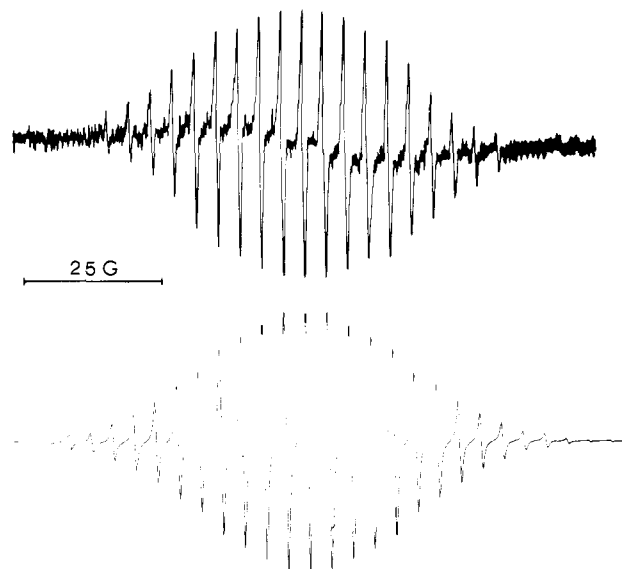
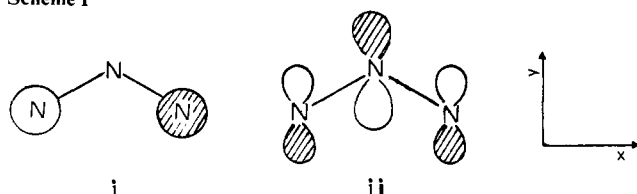

Figure 1. Experimental (top) and computer-simulated (line width 0.45 G) ESR spectrum of 1,3-dimethyltriazaallyl radical (CH<sub>3</sub>NN = NCH<sub>3</sub>) in cyclopropane at -100 °C.

Table I. Experimental and Computed (INDO)<sup>a,b</sup> Hfs Constants (gauss) for the 1,3-Dimethyltriazaallyl Radical (*g* factor is 2.0020)

|                   | Experimental | Computed    |                |
|-------------------|--------------|-------------|----------------|
|                   |              | $\pi$ model | $\sigma$ model |
| 1 N               | 3.9 ± 0.2    | -5.98       | 15.59          |
| 2 N               | 7.7 ± 0.2    | 9.67        | 1.66           |
| 2 CH <sub>3</sub> | 11.6 ± 0.2   | 15.58       | 2.36           |

<sup>a</sup> In the calculations only the NN distance was optimized (1.283 Å for the  $\pi$  and 1.255 Å for the  $\sigma$  configuration). The remaining geometrical parameters have been kept fixed at standard values.  
<sup>b</sup> Only the anti-anti geometry of the 1,3-dimethyltriazenyl radical has been considered. A similar investigation on the relative stabilities of the syn-syn, syn-anti, and anti-anti geometries of the triazaallyl radical has shown that the anti-anti geometry is significantly more stable.

up a  $\pi$ -nonbonding singly occupied molecular orbital (see Scheme I); (ii) a  $\sigma$  radical, where the singly occupied MO consists mainly of an antibonding combination of the nitrogen 2p<sub>y</sub> atomic orbitals (the corresponding INDO percentage is ~80%).

An INDO calculation on the two different electronic configurations<sup>11</sup> showed that model i has an energy 5 kcal mol<sup>-1</sup> lower than ii. This difference is rather small for an unambiguous assignment of the electronic configuration. However a completely different distribution of the spin density should occur in the two cases, in that a much smaller value on the central nitrogen is expected in model i with respect to ii. In Table I it is quite clear that the trend of the hfs constants computed for the  $\pi$  radical is similar to the experimental one, which is certainly not the case for the  $\sigma$  radical. Attempts to fit the experimental spectrum with groups of constants following the trend of model ii were unsuccessful. In no case could the exact sequence of line intensities be reproduced.

It may therefore be concluded that a true allyl-like radical containing three nitrogens instead of carbons has been detected. The calculations also suggested that substitution of methyls with less electronegative groups (e.g., H, SiH<sub>3</sub>) would favor the  $\sigma$  configuration. As a consequence, although the assignment of structure **2** to the radicals of ref 9 (R = silyl substituents) seems quite likely, our finding might suggest a structure of type **1**, with the unpaired electron located on a  $\sigma$  instead of a  $\pi$  molecular orbital.

**Acknowledgment.** One of the authors (L.L.) thanks the C.N.R. (Rome) for financial support and Dr. K. U. Ingold (NRC, Ottawa) for helpful comments, which were made possible by the NATO Research Grants Programme.

### References and Notes

- (1) S. F. Nelsen and R. T. Landis II, *J. Am. Chem. Soc.*, **95**, 2719, 6454 (1973); **96**, 1788 (1974).
- (2) V. Malatesta and K. U. Ingold, *J. Am. Chem. Soc.*, **95**, 6110 (1973).
- (3) V. Malatesta, D. Lindsay, E. C. Horswill, and K. U. Ingold, *Can. J. Chem.*, **52**, 864 (1974).
- (4) L. Lunazzi and K. U. Ingold, *J. Am. Chem. Soc.*, **96**, 5558 (1974).
- (5) R. W. West and B. Bichlmeir, *J. Am. Chem. Soc.*, **95**, 7897 (1973).
- (6) N. Wiberg, W. Uhlenbrock, and W. Baumelster, *J. Organomet. Chem.*, **70**, 259 (1974).
- (7) R. A. Kaba, L. Lunazzi, D. Lindsay, and K. U. Ingold, *J. Am. Chem. Soc.*, **97**, 6762 (1975).
- (8) W. Ahrens and A. Berndt, *Tetrahedron Lett.*, 2295 (1975).
- (9) J. W. Cooper, B. P. Roberts, and J. N. Winter, *J. Chem. Soc., Chem. Commun.*, 320 (1977).
- (10) F. E. Brinckmann, H. S., Haiss, and R. A. Robb, *Inorg. Chem.*, **4**, 936 (1965).
- (11) The program employed is a modification of the standard INDO (available from Q.C.P.E.) that can converge on different electronic configurations. Since the configurations under investigation are of different symmetry, this result can be easily achieved by changing in the appropriate way the occupation of the starting MO's and therefore the guess density matrix.
- (12) Laboratorio C.N.R. Ozzano Emilia, Bologna.
- (13) In partial fulfillment of the requirements for the doctoral degree of the University of Bologna.

F. Bernardi, M. Guerra,<sup>12</sup> L. Lunazzi\*  
G. Panciera,<sup>13</sup> G. Placucci

Istituto di Chimica Organica  
Universit , V. le Risorgimento 4, Bologna, Italy

Received July 10, 1977

### Synthesis and Direct Spectroscopic Observation of a 1,1-Dialkyldiazene. Infrared and Electronic Spectrum of *N*-(2,2,6,6-Tetramethylpiperidyl)nitrene

Sir:

1,1-Dialkyldiazenes (aminonitrenes, *N*-nitrenes) **1**, unlike their more stable 1,2-dialkyldiazene isomers (azo compounds) **2**, have not yet been isolated or detected by spectroscopic

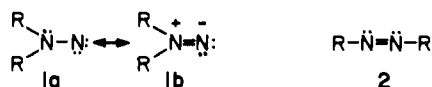

methods, but rather are assumed intermediates based on a substantial body of chemical evidence.<sup>1</sup> Chemical reactions of presumed 1,1-dialkyldiazene intermediates show behavior suggesting that the reacting species is a singlet<sup>1</sup> in contrast to other nitrenes, e.g., alkyl, aryl, carboxy, and cyano nitrenes (*R-N*), which are ground-state triplets.<sup>2</sup> The nature of the bonding and the relative energies of the states of the parent 1,1-diazene ( $H_2N-N$ ) have been the subject of several theoretical investigations, which report that the singlet-triplet splitting may be quite small.<sup>3</sup> Two recent calculations which include extensive configuration interaction predict the singlet is the ground state.<sup>3e,f</sup> GVB-CI calculations by Goddard and Davis<sup>3f</sup> indicate that the dipolar form **1b** makes a substantial contribution to the electronic structure of the 1,1-diazene (Figure 1). Of particular import to the experimentalist is the predicted  $^1A_2 \leftarrow ^1A_1$  transition energy of 2.2 eV<sup>3f</sup> which should be detectable by electronic absorption spectroscopy in the visible region ( $\sim 558$  nm).

We report here the synthesis and direct observation of a 1,1-dialkyldiazene, *N*-(2,2,6,6-tetramethylpiperidyl)nitrene (**3**). The visible spectrum provides the first experimental in-

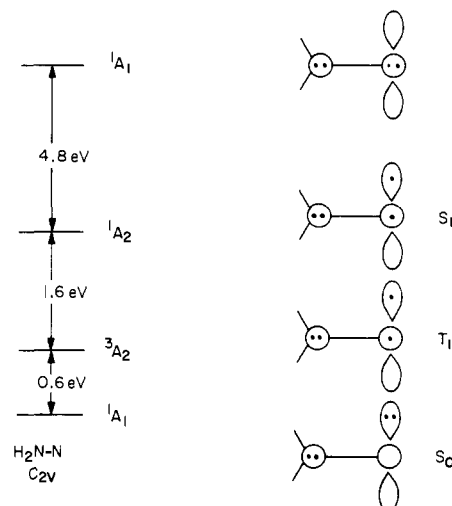
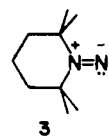

Figure 1. GVB-CI calculations<sup>3f</sup> for  $H_2N-N$  ( $C_{2v}$  symmetry).

formation concerning the electronic structure of a 1,1-dialkyldiazene. Moreover, the infrared spectrum provides evidence that there is considerable double bond character in the  $N=N$  bond, similar to a 1,2-diazene (**2**).



We were encouraged by work in the literature concerning the benefits derived from the synthesis of "persistent" carbon-centered radicals, radicals which may or may not be stabilized by resonance and inductive effects but which are long-lived and therefore subject to spectroscopic inspection because the rate of bimolecular reaction has been drastically slowed down by a steric blockade.<sup>4</sup> It seems reasonable that ordinary elusive 1,1-diazenes with a suitable arrangement of bulky groups would become persistent and therefore easily prepared in relatively high concentrations which would allow their structural and chemical properties to be examined with an ease and accuracy impossible to attain with a transient species.

It is known that oxidation of 1-amino-2,2,6,6-tetramethylpiperidine (**4**) at 50 °C affords hydrocarbon products consistent with the formation and subsequent decomposition of a 1,1-dialkyldiazene intermediate.<sup>5</sup> We find that addition of *tert*-butyl hypochlorite (*t*-BuOCl)<sup>6</sup> to a stirred solution of **4** and triethylamine ( $Et_3N$ ) in anhydrous diethyl ether at -78 °C affords, in addition to an insoluble white precipitate ( $Et_3NHCl$ ), an intense purple solution which is stable for hours at -78 °C, but decolorizes in minutes at 0 °C. Hydrocarbon

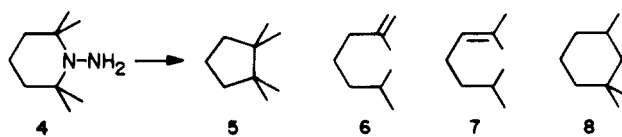

products **5-8** are observed in 14-24% yield in a ratio of 9.7:2.5:24:1.0, respectively.<sup>7</sup> Generation of this colored solution at -78 °C followed by filtration at -78 °C gives a clear purple solution. Low temperature absorption spectroscopy<sup>8</sup> in the visible region on this solution at -78 °C reveals a structured absorption band with two *maxima* at 514 and 543 nm, remarkably close to the  $n-\pi^*$  electronic transition<sup>10</sup> predicted